

Laboratory of alternative energy GverLab

Hydrodynamic Rotary Cavitation Steam Generators
Gver022-Compact and Gver022-Universal

Presentation of innovative heat generation technology

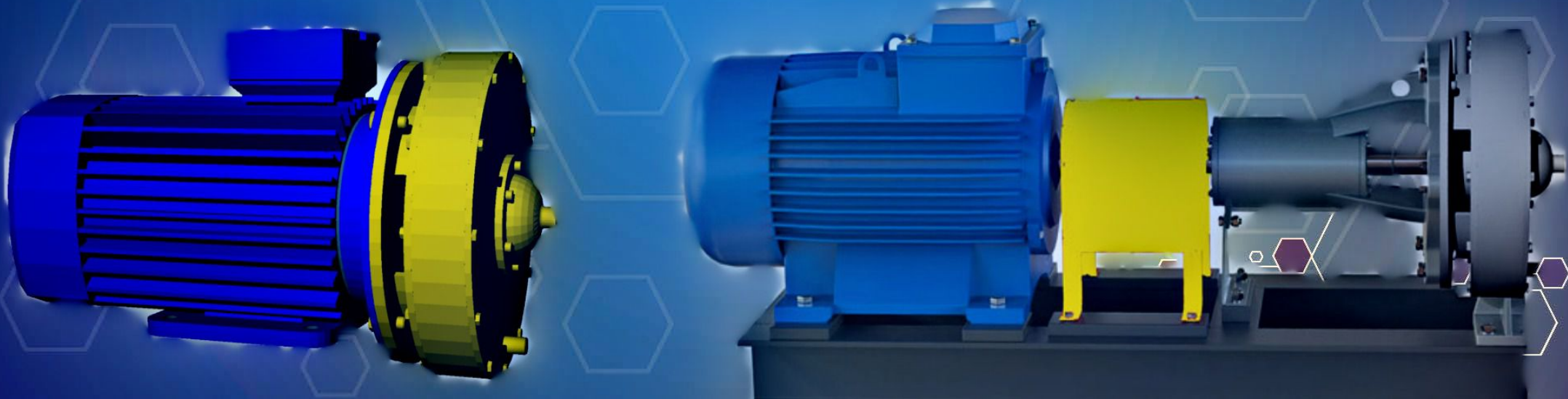

Hydrodynamic Rotary Steam Generators

VS

Conventional (traditional) steam boiler_s

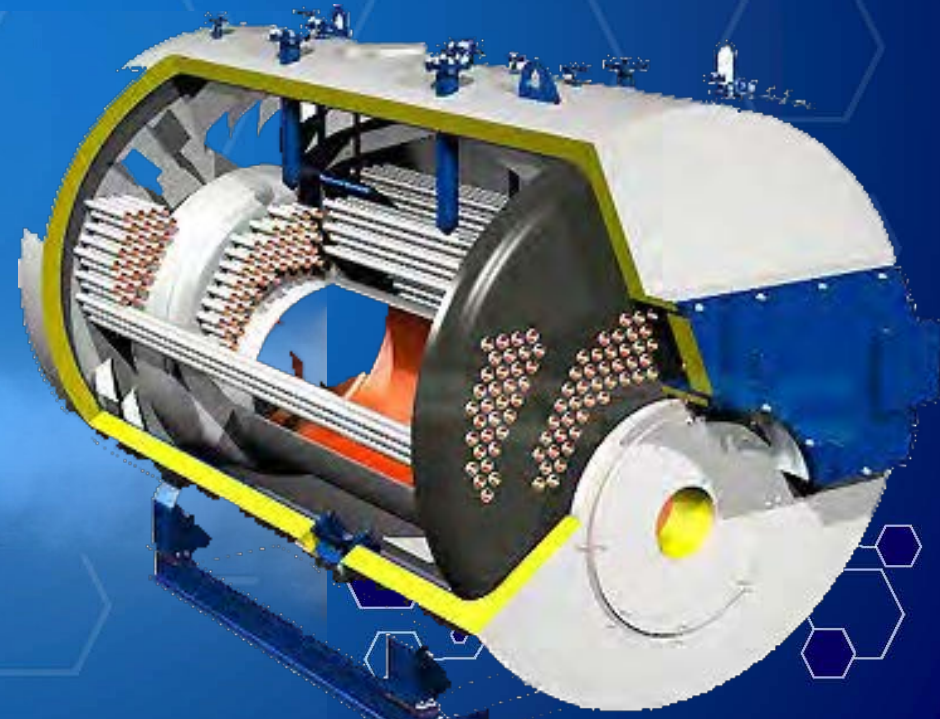
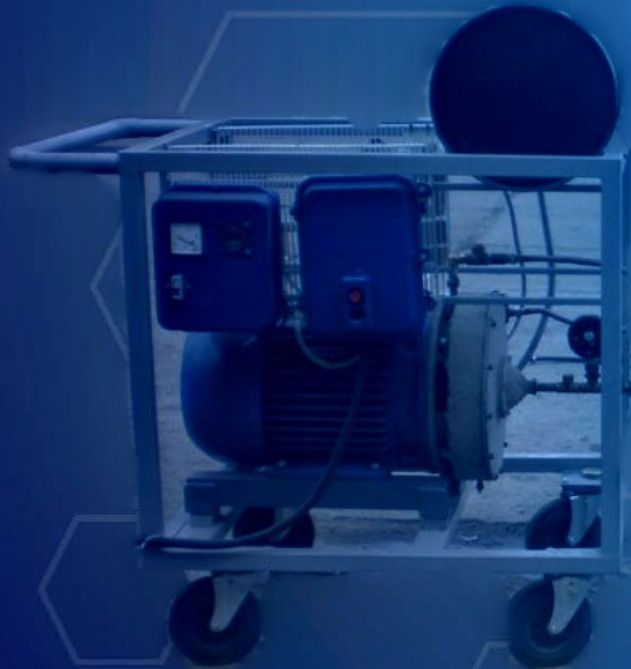

1. Steam generators (steam boilers) - Comparison of efficiency :

Conventional (traditional) steam generators (boilers):

- Electric steam generators with heaters of the thermal heating element, electrodes and induction ones have an efficiency not exceeding 80%.
- Steam boilers operating on solid fuels (coal, wood, various solid waste) have an efficiency not exceeding 50%.
- Steam boilers operating on liquid fuel (heating oil, fuel oil, waste oil) have an efficiency not exceeding 80%.
- Steam boilers operating on natural gas have an efficiency not exceeding 90%.

Hydrodynamic rotary steam generators:

They use electrical energy, have an efficiency significantly exceeding 100% due to mechanical friction of the water layers and generator disks, as well as cavitation and other processes.

Hydrodynamic rotary steam generators are more efficient - they generate 1.2-1.5 times more steam at the same cost of electricity (depending on the model)

2. Steam generators (steam boilers)- Comparison of applied water:

Conventional (traditional) steam generators (boilers)

- Electric steam generators with heaters of thermal heating element, electrode and induction - chemical water treatment is required.*
- Steam boilers operating on solid fuels (coal, firewood, various solid waste) - chemical water treatment is required. equired.*
- Steam boilers operating on liquid fuels (heating oil, fuel oil, waste oil) - chemical water treatment is required*
- Natural gas fired steam boilers - chemical water treatment is required.*

Hydrodynamic rotary steam generators

- chemical water treatment is not required.*



3. Steam generators (boilers) - comparison of explosive security:

Conventional (traditional) steam generators (boilers):

- Electric steam generators with heaters of thermal heating element, electrode, induction - it is necessary to comply with precautions and installation of safety valves.*
- Solid fuel steam boilers (coal, wood, various solid waste) - it is necessary to comply with precautions and installation of safety valves.*
- Steam boilers operating on liquid fuel (heating oil, fuel oil, oil) - it is necessary to comply with precautions and installation of safety valves.*
- Natural gas fired steam boilers - it is necessary to comply with precautions and installation of safety valves.*

Hydrodynamic rotary steam generators:

Fully explosion safety - there are no containers under pressure, all water vapor that is produced is immediately directed outside the steam generator, without intermediate storage in additional tanks under pressure.



Hydrodynamic rotary steam generators - Other advantages:

- the possibility of obtaining a steam, a steam-water mixture, hot water;*
- quick access to the "working mode", especially in short-term and cyclic work;*
- any work mode : short-term, long, continuous;*
- full autonomy: when equipped with an internal combustion engine;*
- reliability : the steam generator practically does not contain constructive elements,*
which in the process of work are prone to wear and has a much larger working resource in relation to other types of steam generators;
- not difficult service : thanks to the simple design and use of nodes, designed for prolonged multi-year exploitation;*
- all maintenance of the steam generator is only periodically controlled by the state of the water filter and an electric motor control unit.*

- The steam generator rotor can be rotated by a diesel engine corresponding power, therefore hydrodynamic rotary steam generators are more economic and universal.*





Today, the actual task is to increase energy efficiency with lower operating costs and a minimum negative impact on the environment.

Heating with traditional boilers



*Environmental pollution;
Low efficiency of electric and coal-fired boilers COP = 0.8 and 0.5;
Excessive waste of natural resources;
Significant energy losses;
The high cost of repairing boiler equipment;*

Heating with Hydrodynamic rotary steam generators

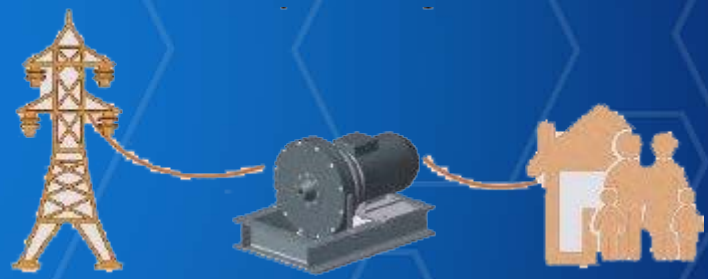

*No harmful emissions;
High energy efficiency min COP = 1,2;
Low operating costs (generator does not require daily monitoring);
Reducing the consumption of primary energy resources.*



Cavitation technology - short review



*Cavitation
bubbles form*

*Bubbles
collapse*



Cold water

*High speed
Low pressure*

*High speed
High pressure*

Hot water and steam

The liquid is fed into the cavitation channels in the composite rotor and the cavities between the stator and rotor discs. Mechanical friction between the layers of water and the surfaces of the stator and rotor disappears.

*Cavitation
bubbles form*

Liquid enters the area of low velocities and high pressures of cavitation channels. Cavitation bubbles collapse with the formation of a cumulative flow.

Through the flow, the heated vapor and gas contained in the bubble are injected into the liquid surrounding the bubble and onto the working surfaces of the device, increasing their temperature, heating the coolant.

The history of the development of hydrodynamic cavitation rotary heat generators: the cells of the inventor Griggs.

The founder of this direction in heating engineering - James L. Griggs, being a specialist in heating systems, worked as the chief engineer of a small company Hydro-Dynamic Inc. near Atlanta in Georgia (USA). Initially, in the late 80s, the inventor set out to create not a device that generates excess thermal energy, but only a frictional water heater of the most simple design. The drawings from his patents show options for mounting the rotor part on one and two support bearing assemblies.

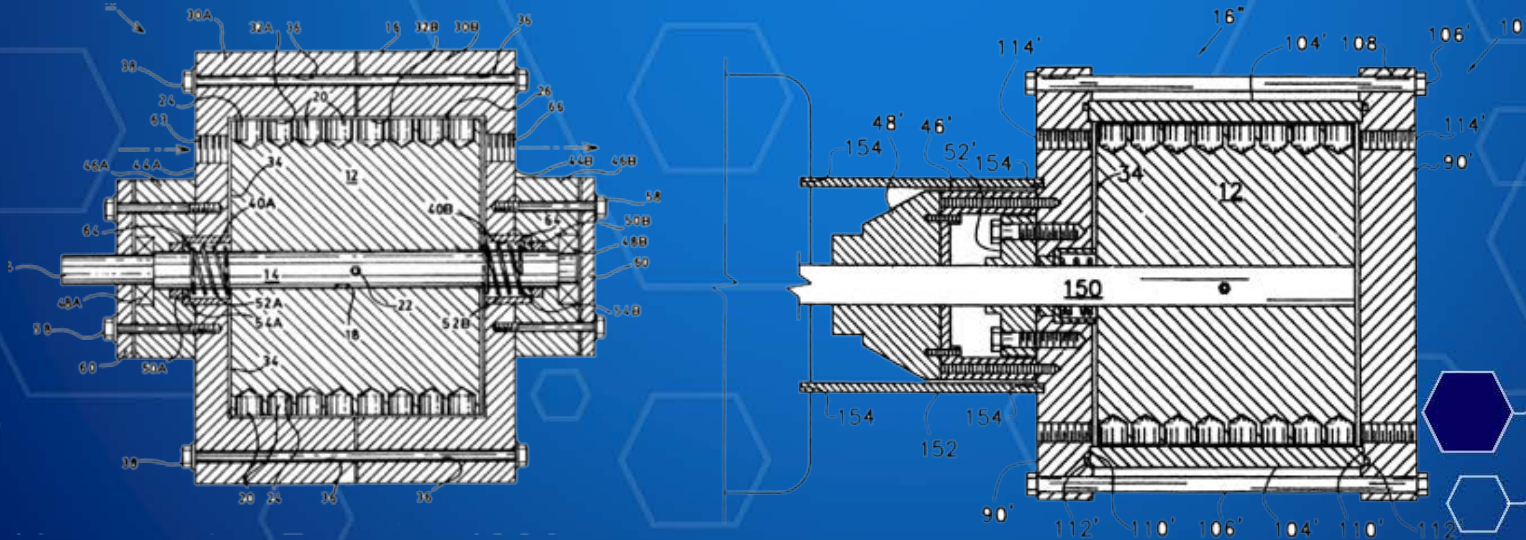

The history of the development of hydrodynamic cavitation rotary heat generators: developments of Ukrainian inventors .

The cavitation-rotor heat generator consists of a body with an inlet and outlet for the heated liquid, which has a cylindrical cavity and two coaxial rings placed in it, one of which is fixed motionless relative to the body, and the other is driven into rotation from a drive shaft coaxial with the rings. The rings are equipped with radial holes located in a plane perpendicular to the axis of rotation. The outer coaxial ring is made rotating, and the inner one is fixed relative to the body, while the gap between the rotating outer ring and the inner cylindrical surface of the body is from 0.5 to 3 mm. Drawings from patents:

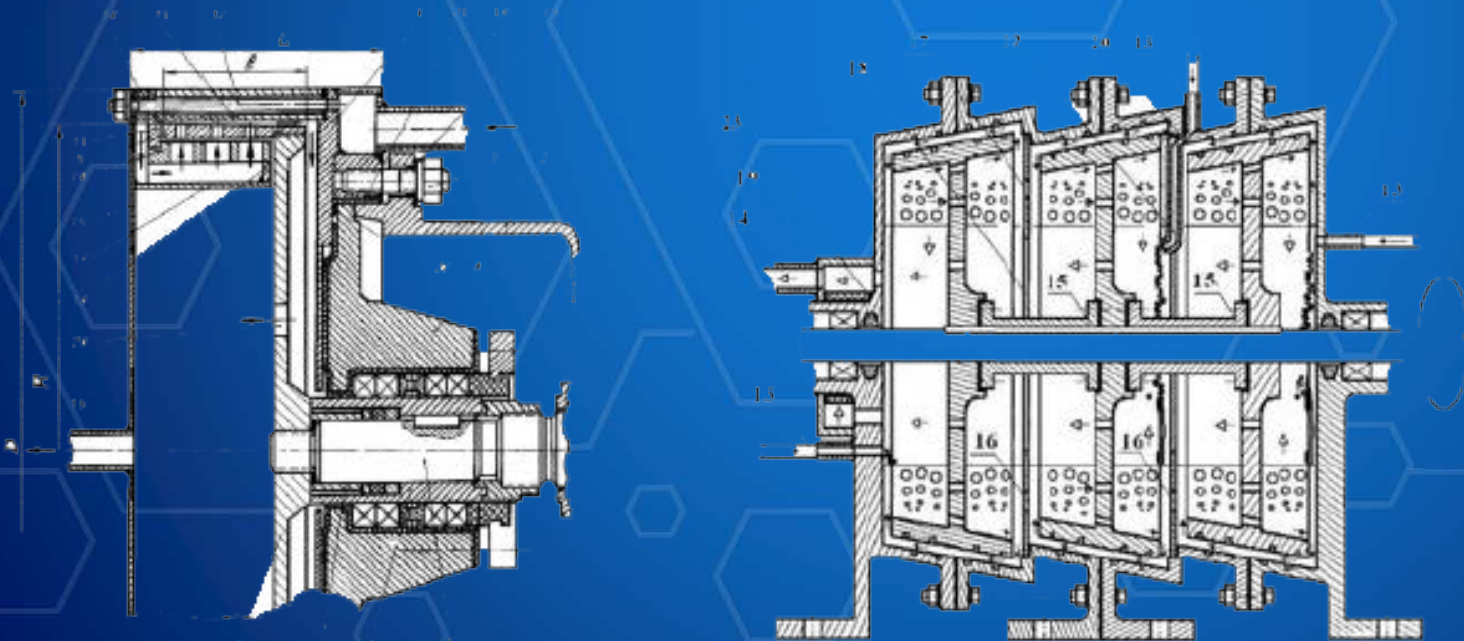

Technology of hydrodynamic cavitation rotary steam generators created by the laboratory of alternative energy Gverlab together with our Ukrainian partners - the brief description.

Hydrodynamic heating of the device and the liquid occurs in the zone farthest from the axis of rotation at an increased pressure created during the rotation of the multilayer volume of the liquid. During the operation of the rotor, the vapor-generating liquid turns into a multilayer ring, rotates with a steam funnel inside and, due to the higher rotation speed of the rotor, is intensively pumped into the working gap and heats up in it to temperatures exceeding the normal boiling temperature. The liquid displaced from the layer rises to the interface due to the difference in density and inertia of motion, expands into rotating small layers and rings. Then the superheated liquid boils, vapor bubbles are separated at the interface, creating a product flow, while the temperature of the ascending liquid flows decreases due to expansion and boiling at reduced pressure and cooling by counter descending flows. Under the action of rapid compression in the flow, the bubbles collapse with the release of additional heat, which is added to the heat obtained due to friction with structural elements, while increasing the heating efficiency (mixing or disinfecting) water. In addition, as a result of the collapse of cavitation bubbles, high-amplitude energy impulses appear, accompanied by hydraulic shocks with a duration of several nanoseconds and the concentration of the energy of such impulses in discrete local working zones of nanometer sizes, as well as the association (synthesis) of water molecules.



Technology and design of hydrodynamic cavitation rotary steam generators created by the Gverlab laboratory together with our Ukrainian partners: the drawings from our patents and photos.

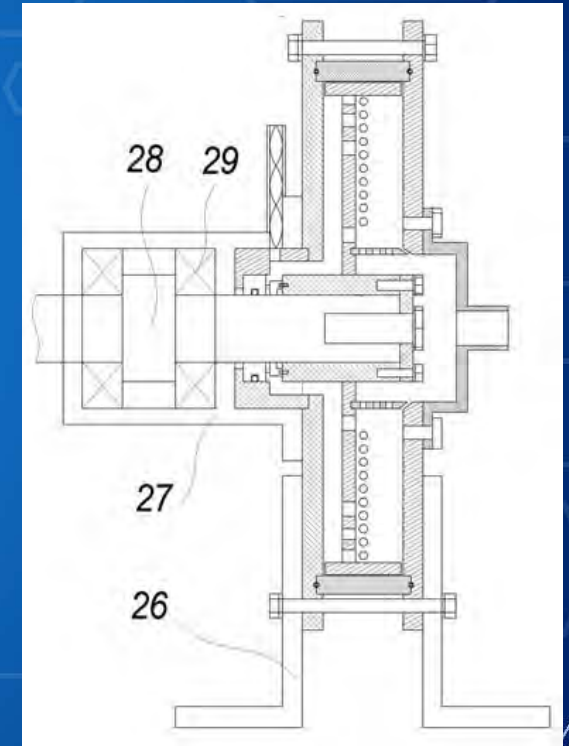
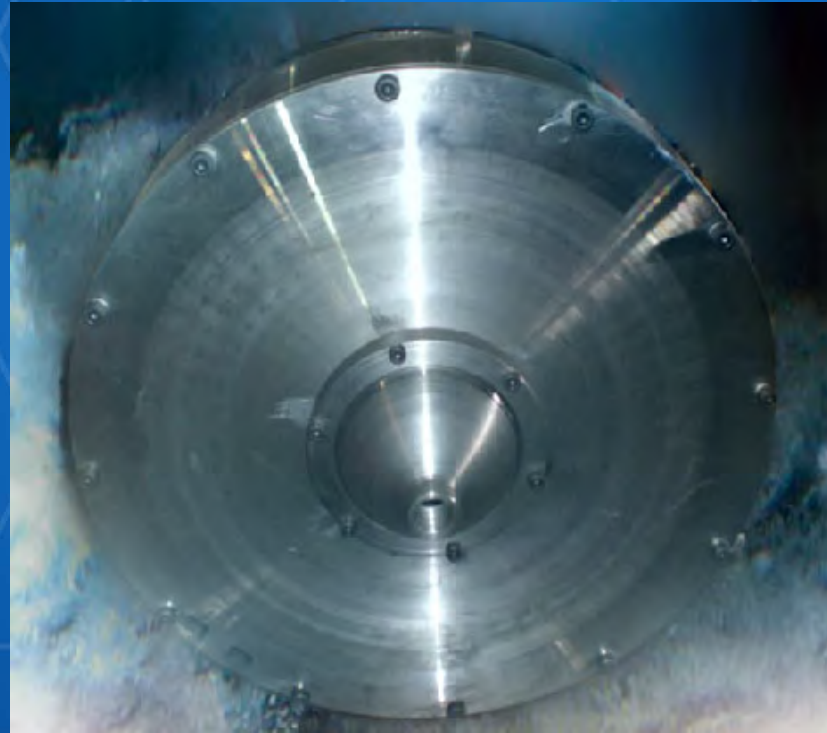
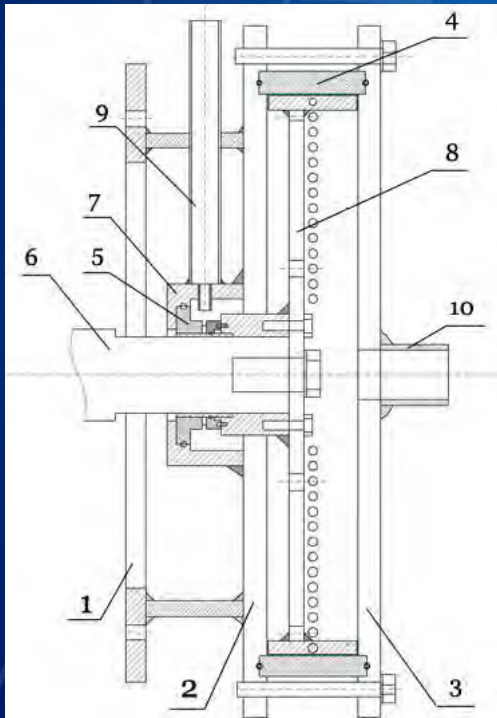

Hydrodynamic rotary steam generator GVER022- model Compact



Main technical characteristics of the steam generator:

- Electric power consumption - 23 kW*
- The amount of steam produced - 40 kg / hour or 100 kg/h of steam-water mixture*
- Working outlet steam temperature - 140 ° C*
- Working pressure of team at the outlet - 0,4 MPa*



Hydrodynamic rotary steam generator GVER022- model Universal



Main technical characteristics of the steam generator:

- Electric power consumption - 23 kW*
- The amount of steam produced - 40 kg / hour or 100 kg/h of steam-water mixture*
- Working outlet steam temperature - 140 ° C*
- Working pressure of team at the outlet - 0,4 MPa*



Additional parameters of steam generator GVER022:

MOTOR - Rated power, P_{nom} - 22 kW, AC frequency - 50 Hz, rated current - 42,7 A, 3000 rpm, energy conversion factor of our steam generator - (COP) - 1,27

The amount of generated steam-water mixture with a temperature of up to 90 degrees Celsius - 100 liters per hour.

Advantages of our steam generators :

- no need for special preparation of water - any only filtered water is used,*
- complete safety in use - there is no possibility of an explosion (because there is not a tank with water vapor under pressure,*
- our devices are more economical (by 25 percent, compared to classic steam generators)*
- our devices quickly produces the working steam - 5 minutes after the start,*
- there are no heating elements in our steam generator , no need to replace it ,*
- the calculated devices life - the warranty period - 12 years.*



Hydrodynamic rotary steam generators are used in the following main areas:

1. Autonomous repair and restoration work in the winter time

- for heating the mains for supplying water and heat in settlements, foundations of houses, wells for cable ducts and communications; well rings, well bottoms, well covers; trays: drainage, rainwater, drainage, road, heating mains cover trays;

2. Energy

*- hot water supply and heating of industrial premises;
- when unloading fuel oil and other thick fuels and lubricants for heating them and steaming containers, for defrosting pipes, for heating viscous media (oil, fuel oil);*

3. Building

*- for steaming concrete and reinforced concrete products;
- for the production of paving slabs, curbs, artificial decorative **stones**, elements of small garden architecture, products from foam concrete, polystyrene concrete, expanded polystyrene concrete, aerated concrete, gas silicate, pin-silicate; expanded clay concrete blocks, cinder blocks; lids of trays, ready-mixed concrete, polystyrene;
- for heating concrete, crushed stone and sand in winter;
- for heating bitumen;
- to increase humidity when drying valuable wood species, as well as drying lumber;*



4. Food and processing industry

- disinfection and sterilization of technological lines, containers and tanks for milk, wine, juice, kvass, extracts;*
- sterilization of milk, cooking cheese mass, condensed milk, sausages in chambers, production of beer, sunflower oil, juices, cool drinks, various canned food;*
- in the meat-processing industry for the defrosting of fish and meat;*
- production or cooking of various confectionery masses, which are heated in boilers by supplying steam to the steam jackets of these boilers.*

5. Agricultural sector

- disinfection, steaming the soil with steam in greenhouses;*
- dressing the soil in the greenhouse;*
- air humidification in greenhouses;*
- growing mushrooms in greenhouses;*
- preparation of the substrate for growing mushrooms;*
- for brewing feed and the production of pelleted feed.*

6. Pulp and paper industry

- production of corrugated packaging, paper, cardboard, plywood;*
- heating of drying drums;*

In addition, steam generators are used for: bakeries, saunas, laundries, dry cleaners, cleaning and washing with steam, for washing cars, cleaning automobile units from dirt during their repair.

All our projects green energy are carried out in close cooperation with a group of strategic investors, such as FOP Morozov and others and a number of talented Ukrainian engineers and inventors.

The creative team of engineers, scientists, inventors and business partners of the Laboratory of Alternative Energy GVERLAB invites interested persons and companies to cooperate for joint further development and improvement, development, manufacture and implementation of energy-saving devices.

Contacts: 09100, Ukraine, Kyiv, gver.tk@gmail.com